

# KM-320/515MAH-E

## SLIM-LINE MODULAR CRESCENT CUBER

Item # \_\_\_\_\_

Project: \_\_\_\_\_

Qty: \_\_\_\_\_

\*AutoCad available on KCL

KM-320/515MAH-E

10/10

Item # 13125

### CUBER DIMENSIONS W x D x H

**KM-320/515MAH-E**  
56 x 69.5 x 77cm

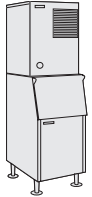

KM-320/B-300

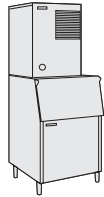

KM-320/B-500

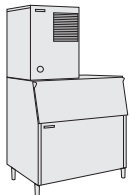

KM-320/B-700



KM-515/B-300



KM-515/B-500

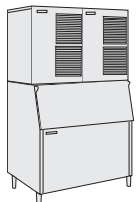

KM-515/B-700

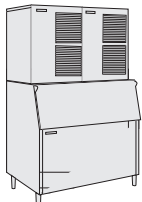

KM-515/B-800

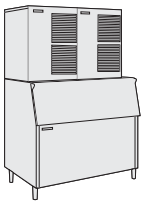

KM-515/B-900

Also available on Large Bins:  
B-1150SS  
B-1300SS



### KM-320MAH-E

Air-Cooled  
Shown

### KM-515MAH-E

Air-Cooled



### KM-320MAH-E

- Up to 133 kgs. of ice production per 24 hours

### KM-515MAH-E

- Up to 233 kgs. of ice production per 24 hours
- Mount two units side by side for 466 kgs. per 24 hours

### KM-320MAH-E & KM-515MAH-E

- Durable stainless steel exterior
- Individual crescent cube
- Protected by *HoshiGuard* Antimicrobial Agent 
- CycleSaver® Design 
- EverCheck® alert system 
- Stainless steel evaporator
- Removable air filters
- R-404A Refrigerant



### Warranty

Contact factory for warranty information.



# Hoshizaki

## KM-320/515MAH-E SLIM-LINE MODULAR CRESCENT CUBER

**DIMENSIONS**  
W x D x H  
**KM-320/515MAH-E**  
56 x 69.5 x 77cm

• Air-cooled

### AIR-COOLED - KM-320MAH-E

Water Temp° C.	10°	21°	32°	
Air Temp° C.	21°	133	125	116
	27°	127	114	106
	32°	125	<b>105</b>	97

### AIR-COOLED - KM-515MAH-E

Water Temp° C.	10°	21°	32°	
Air Temp° C.	21°	233	219	200
	27°	222	200	182
	32°	219	<b>185</b>	166

### UTILITY CONSUMPTION at 32°C A/ 21°C W

Model Number	Ice Production Per Cycle		KWH per 45 Kgs.	Potable Water Liters per 45 kgs.	Condenser Water Liters per 45 kgs.
	Kgs.	Cubes			
KM-320MAH-E	3.6	360	7.3	84.0	N/A
KM-515MAH-E	4.6	480	7.1	100.3	N/A

### SPECIFICATIONS

Model Number	Condenser	Amperage	Min. Circuit Ampacity	Shipping Weight
KM-320MAH-E	Air-Cooled	3.5	15 A	79 kgs.
KM-515MAH-E	Air-Cooled	7.14	15 A	79 kgs.

### STORAGE BINS

Model Number	Application Capacity
B-300	136 kgs.
B-500	227 kgs.
B-700	318 kgs.
B-800	363 kgs.
B-900	409 kgs.
B-1150	522 kgs.
B-1300	578 kgs.

### ELECTRICAL & PLUMBING/KM-320/515MAH-E

- 220-240/50/1
- 15 Amp Max Fuse
- 0.95cm OD copper or equivalent independent potable water supply
- 3/4" FPT independent drain connection

### OPERATING LIMITS

- Ambient Temp Range 7 - 38°C
- Water Temp Range 7 - 32°C
- Water Pressure 0.7 - 8 kg/cm<sup>2</sup>
- Voltage Range 198 - 254V

### SERVICE

- Panels easily removed and all components accessible for service.
- Removable/cleanable air filters

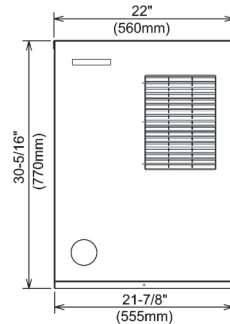

KM-320 FRONT VIEW

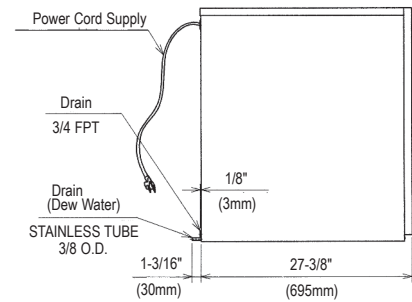

KM-320 SIDE VIEW

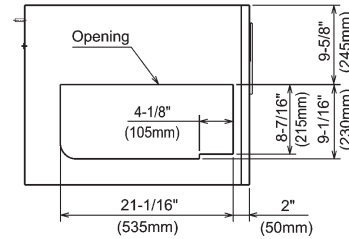

KM-320/515 ICE DROP ZONE

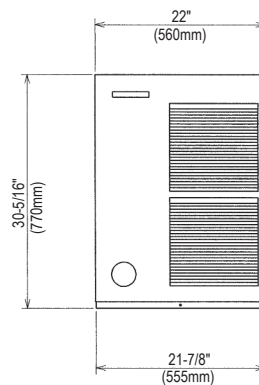

KM-515 FRONT VIEW

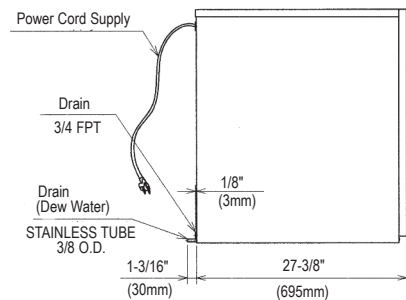

KM-515 SIDE VIEW



© HOSHIZAKI AMERICA, INC.

618 Hwy. 74 S., Peachtree City, GA 30269

TEL 1-800-438-6087

FAX 1-800-345-1325

www.hoshizaki.com

Printed in U.S.A.

